



T-Max® 3W G2 User's Guide

Supplied Components

- 1, T-Max® 3W G2 Interface Timer
- 1, 9VDC or AC Power Supply
- 1, T-Max® 3W G2 User's Guide
- 1, 50' Modular Cable with RJ-22 connectors on both ends

Specifications

- Power Supply** 9-12 VDC or AC @ 300mA
- Dimensions** Cover Plate: 5.25" x 5.25"
PCB: 2.5" x 3.25" x 1.5"
- Relay** 220V @5A SPST

Physical Connections

Connect the two wires from the tanning bed, for attaching to an external timer, to the "contact" screw terminals on the T-Max® 3W G2.

Note: There may be many wires visible on the tanning bed. Two of these wires are specifically used for connecting the tanning bed to an external timer. If you are not sure which two wires to use, refer to the tanning bed's manual or contact the tanning bed's manufacturer.

Connect the 9V @ 300mA transformer to the screw terminal labeled "PWR IN 9-12V" on the back of the T-Max® 3W G2. Plug the transformer into a 120VAC outlet.

Initial configuration

When power is first applied to the timer the display may show a 99. Press and release the Start/stop button and the display will flash 88. Press and release the Up button and the flashing 88 will stop. The timer is now ready to be used as a stand alone timer.

Setting Parameters

Note: If you are using a T-Max® Manager or T-Max® Manager/Pro and multiple T-Max® 3W G2s, remove power from the T-Max® Manager or Pro. Keep power removed from the T-Max® Manager or Pro until all parameter changes are complete.

- 1) Apply power to the T-Max® 3W G2
- 2) Press and hold the Start/Stop and Up buttons together on the T-Max® 3W G2 until a "P-" appears on the display. Release the buttons. Once the buttons are released the display will read a .1 (point one).
- 3) Press the Up and Down Buttons until the parameter number that you want is displayed.
- 4) Press the Start/Stop Button to observe the current value for that parameter.

The Display will show a number with a period in the lower center of the display. The numbers will be flashing. The number shown is the current value for that parameter.

For Lamp Hours, Session Counts, etc. the value displayed can be as high as 9999. To display this value, the T-Max® 3W G2 will flash two numbers-three times, then two numbers-three times, pause, two numbers-three times, two numbers-three times, pause, etc. For example, if you are checking lamp hours (Parameter 6) and the display flashes the numbers 53 three times, then 14 three times, pauses then repeats, then the total lamp hours stored in that T-Max® 3W G2 is 5314.

- 5) Press the Up or the Down button to change the parameter to the desired value.

If you want to clear the value for that parameter, press the Up and Down buttons at the same time until the display flashes "0.0".

- 6) Press the Start/Stop Button.

The display will show the parameter number you just changed and a solid period in the lower center of the display. You may now change another parameter by pressing the Up and Down buttons until the parameter you want displayed. Repeat Steps 2-4.

- 7) To exit the Parameter mode press and hold the Up and Down buttons together until the period goes away.

Parameter Numbers for Observing and Changing Parameters.

Parm	Description	Max	Default	Notes
1	Address	255	254	Address of T-Max® 3W G2
2	Beep Mode	1	0	Used for High Power beds. 0=Alarm only, 1=Alarm and Flip
3	Delay Time	10	0	Delay in minutes stored in the T-Max® 3W G2.
5	Session Counts	65535	0	Total session counts for T-Max® 3W G2s.
6	Lamp Hours	65535	0	Bulb hours for each bed.
7	Bed Hours	65535	0	Number of hours a bed is on.
8	Manual Session Counts	65535	0	Counts the number of sessions the T-Max® 3W G2 has run while in Stand Alone Mode
9	Clean Room	1	1	0 = Clean Room Disabled, 1 = Enabled
10*	Manual Lockout	1	0	0 = Stand Alone Enabled, 1 = Disabled
13	Cool Down Mode	10	0	0 = Disabled, 1-10=Enabled. Time delay in minutes allowing bed to cool.
15	Fixed Session Counts	65535	0	Counts number of sessions ran through the T-Max® 3W G2. This value cannot be changed at all. Used as point of reference.
20	External Speaker	1	0	0 = Speaker on T-Max® 3W G2, 1 = External Speaker will be used.
21	Pause Mode	1	0	0 = When session is paused, time will continue to count down. 1 = When session is paused, session time will stop counting down.
22	Auto Bed Shut Off	1	0	For T-Max® Intercom Systems Only. 0 = When timer is called bed will stay on, 1 = When timer is called, bed will stuff off automatically.
24	Max Address	1	0	0 = The T-Max® 3W G2 will only go to address 99. 1 = T-Max® 3W G2 will go to address 128.
25	Start/Stop Clean Room Clear	1	0	0 = Only the Set button can be used to clear the Clean Room. 1 = Either the Set or the Start/Stop button can be used to clear the clean room.

IN-ROOM SINGLE BED CONTROL

Running a session

Press the Up or the Down Button on the T-Max® 3W G2 until the session time is displayed. If the display shows a 0, and you want to go directly to the maximum time, press the down button once. Press and release the Start/Stop button to start the session. If a delay other than 0 is entered, the delay will count down. A period on the lower right corner of the display will flash rapidly. When the session starts, the period will flash at a once per second rate. If you want to energize the tanning bed before the delay time expires, press and release the Start/Stop button again.

To pause a session, press the Start/Stop button on the T-Max® 3W G2. The flashing period on the lower right corner of the display will stop flashing. The tanning unit will de-energize. Press the Start/Stop button on the T-Max® 3W G2 to re-start the session. The period on the lower right corner of the display will resume flashing. The tanning unit should re-energize.

To cancel a session press the Start/Stop button on the T-Max® 3W G2 to pause the session. Then press and hold the Up button until the display shows a 0 or two dots if the clean room parameter is enabled.

REMOTE SINGLE BED CONTROL (Master-Slave)

Remote single bed control is the ability to control a T-Max® timer in the tanning room with a T-Max® 3W G2 at the front desk. Two T-Max® timers are required for remote single bed control: A T-Max® 3W G2 at the front desk (referred to as the Master) and a T-Max® timer in the tanning room (either a T-Max® 3W G2 or a T-Max® certified in bed timer. This timer is referred to as the slave). A Master T-Max® 3W G2 can only control one T-Max® timer in the tanning room.

WIRING

Place one T-Max® 3W G2 in the tanning room and one at the desired remote location. Connect the 9V @ 300mA power supply to the “Pwr In” screw terminal on the back of each T-Max® 3W G2. Plug each power supply into a 120VAC outlet. Connect the T-Max® 3W G2 in the tanning room to the tanning bed as described.

Run the provided modular cable from the tanning room to the remote T-Max® 3W G2. Connect the modular cable to one of the RJ-22 ports on each T-Max® 3W G2.

Note: If you are using the G2 wireless adapters, you do not need to run the modular cable. Connect the G2 access point to the T-Max® 3W G2 RJ-11 connector shown in the diagram in this document and as described in the G2 Access Point documentation.

CONFIGURATION

Set the address on the T-Max® 3W G2 in the tanning room to “1”, and the address on the T-Max® 3W G2 at the front desk to “0” as described in the setting parameters section of this manual. When setting the address (parameter 1), make sure the period is not flashing. A flashing period means the address is over address 100.

When setting the delay (parameter 3), set the delay on the Master T-Max® 3W G2 (the T-Max® 3W G2 at the front desk).

SESSION CONTROL

To start a session, press the Up or Down Button on the T-Max® 3W G2 at the front desk until the session time is displayed. Next press the Start/Stop button on the front desk T-Max® 3W G2 to start the session.

If a delay other than 0 is set, the delay will count down. A period on the lower right corner of the display will flash rapidly. When the session starts, the period will flash at once per second rate. If there is no delay entered, the session will start immediately.

To pause a session, press the Start/Stop button on the timer in the tanning room. The flashing period on the lower right corner of the display will stop flashing and stay illuminated. The session time will continue to count down and reflect the remaining session time. To restart the session, press the Start/Stop button on the timer in the tanning room. The period will continue flashing.

To Cancel a session Press the Up and Down buttons on the T-Max® 3W G2 at the front desk at the same time.

CLEAN ROOM

Once the session time has elapsed, the display will show two solid periods only. This is an indication that the room needs to be cleaned. To clear the clean room indication, press and hold the Up button on the T-Max® 3W G2 in the tanning room until the two periods disappear and a “0” appears. To disable the clean room feature, set parameter 9 to a 0.

CONNECTING THE EXTERNAL SPEAKER TO THE T-MAX® 3W G2

An external speaker can be added to the T-Max® 3W G2 to provide a louder alarm. Simply connect the External Speaker to J6 on the back of the T-Max® 3W G2. Set Parameter 20 to a 1 to enable the External Speaker as described in the setting parameters section.

FIGURE - FRONT AND REAR VIEWS OF THE T-Max® 3W G2



Front View of T-Max® 3W G2

- J4 - PWR IN 9-12V:** Connect 9-12V power supply to this terminal.
- J3 - Contact:** Connect the two wires from the tanning bed to these screw terminals.
- J6:** Connector to connect external speaker for higher volume alarm.
- EXT Start** – Connects to momentary external start button.
- TPI** - Connects to front desk controller not made by Applied Digital, Inc.
- RJ-11** – Connects to the G2 Access point for wireless communications.
- RJ-22** – Connects to T-Max® cable for wired

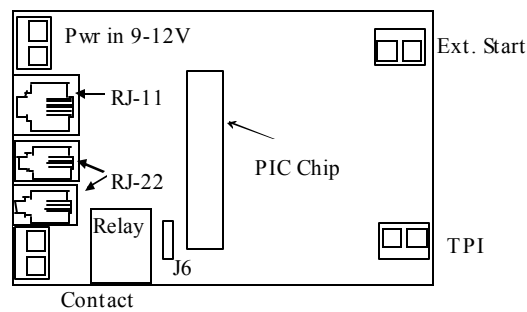

Rear View of T-Max® 3W G2 PCB

(C) COPYRIGHT 1995-2011 By Applied Digital, Inc.

The information in this manual is believed to be correct. However, Applied Digital, Inc. assumes no responsibility for any errors herein. This information is subject to change without notice, and should not be construed as a commitment by Applied Digital, Inc.

WARRANTY

This product is warranted against defective materials and workmanship for a period of two years from date of purchase. In the event the product fails to perform, it may be returned; Shipping Paid, to the factory to be serviced or replaced at the factory's discretion. Applied Digital, Inc. will pay to ship the repaired or replaced product by the shipping means of our choosing. Returns will not be accepted without a Return Authorization Number assigned by the factory.

It is a Condition of Sale that the user of Applied Digital Inc.'s products assumes all risk and responsibility of use and indemnifies Applied Digital, Inc. against all damages. Applied Digital, Inc. is not liable for loss of profits, lost savings, special, incidental, consequential, indirect or other similar damages arising from breach of warranty, breach of contract, negligence, or other legal action even if Applied Digital, Inc. or its agent has been advised of the possibility of such damages, or for any claim brought against you by another party. This warranty allocates risks of product failure between the purchaser and Applied Digital, Inc. Applied Digital, Inc.'s hardware pricing reflects this allocation of risk and the limitations of liability contained in this warranty. It is a violation of the stated warranty to cut or modify the provided modular cables supplied with the T-Max® Series Timers. Connecting the T-Max® Series to third party timers not approved by Applied Digital, Inc. also violates the stated warranty. Contact your dealer or Applied Digital, Inc. to determine if your third party timer is approved by Applied Digital, Inc.